

该系列是一款90°部分回转电动驱动装置。适用于球阀、蝶阀、旋塞阀、旋球阀等阀门。箱体采用精密铸造，样式新颖，外形美观。采用蜗轮蜗杆传动，蜗轮副自锁，使用圆锥滚子轴承，传动更加灵活，效率高。蜗轮材质可根据阀门开启次数以及电装转速选择(ASTM A536 65-45-12, QA15, D2)等材料，蜗轮与阀门阀杆连接部分有实体和内置螺母两款供客户选择，法兰全部采用ISO5211国际标准，与阀门配套更加方便。还可根据客户需求订做基座式连接，便于风门使用。与电装对接部分可选择ISO5211, JB2920-81等连接形式。防护等级为IP65, 特殊环境还可做到IP68。

This series of products is quarter turn electric gear actuator. Suit to be used in ball valves, butterfly valves, plug valves, rotary ball valves etc. The housing made by precise casting, new design, nice appearance. It transmitted by worm gear and worm. The worm gear with self-locking. With tapered roller bearing, so the gearboxes can be operated more flexibly and have higher efficiency. Worm gear material choose ductile iron, aluminum bronze or D2, according to open times and electric actuator speed. Two connection types for choose: stem and key connection and removable nut type. Can produce based type gearboxes used in damper valves. The output mounting flange adapts to ISO 5211. So the gearboxes installed on the valve are very convenient. Input flange adapts to ISO 5211, JB2920-81 etc. General products protection grade is IP65. For special environment can be done IP68 and immersion.

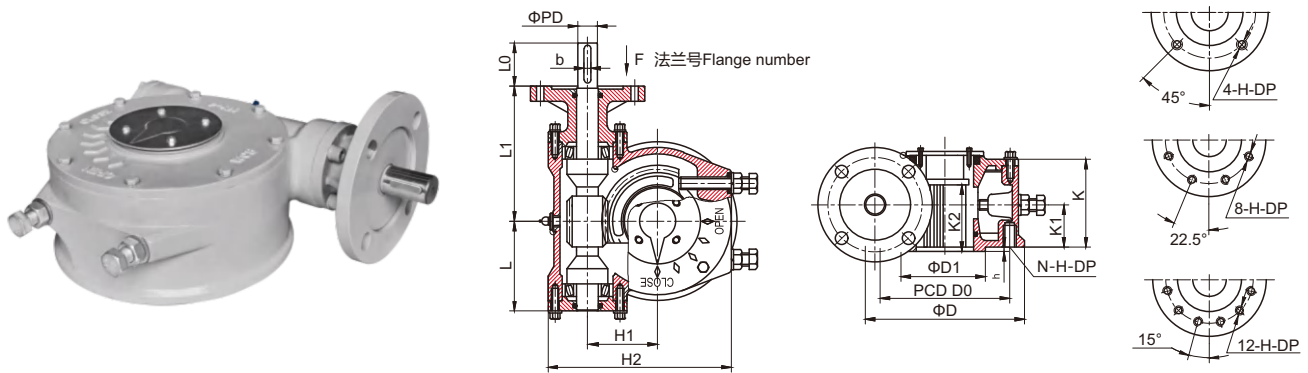

型号 Model	MY-00D	MY-0D	MY-1D	MY-2D	MY-3D	MY-4D	MY-5D	MY-6D	MY-7D	MY-8D	MY-9D	MY-10D	
技术参数 TECHNICAL-PARAMETERS													
速比 Ratio	33:1	39:1	46:1	49:1	53:1	60:1	62:1	67:1	65:1	78:1	70:1	80:1	
最大转矩 Max-torque	N·m	800	1200	1800	3500	5000	10000	18000	22000	40000	58000	80000	150000
	kgf·M	81.6	122.4	183.6	357	510	1122	1836	2245	3061	5510	8163	12245
传动效率 Transmission efficiency	M.A. ±10%	0.3	0.3	0.3	0.3	0.3	0.3	0.3	0.3	0.3	0.3	0.3	
连接尺寸 CONNECTION-SIZE													
法兰号 FLANGE	F10	F12	F14	F16	(F20)	F25	F30	F35	F40	F48	F60	F60	
法兰外圆(D)	125	150	175	210	250	300	350	415	475	560	686	686	
连接孔中心PCD	D0	102	125	140	165	205	254	298	356	406	483	603	
	N-H-DP	4-M10-15	4-M12-18	4-M16-24	4-M20-30	8-M16-24	8-M16-24	8-M20-27	8-M30-45	8-M36-54	12-M36-54	20-M36-54	20-M36-54
凸面 Convex (D1×h)	70×3	85×3	100×4	130×5	140×5	200×5	230×5	260×5	300×8	370×8	470×8	470×8	
最大阀杆 mm (Φ)Max-Stem-Diameter	30	38	45	55	65	80	105	115	140	155	200	220	
	8×7	10×8	14×9	16×10	20×12	22×14	28×16	32×18	36×20	40×22	45×25	50×28	
电装连接 Input Shaft	PD×b(key)	15×5	20×6	20×6	30×8	30×8	35×10	40×12	50×14	50×14	60×18	70×20	
	L0	30	40	40	55	55	60	60	65	80	80	100	
外形尺寸 APPEARANCE-SIZE													
H1	55	66	75	92	111	145	160	200	225	270	315	355	
H2	153.5	198.5	217.5	277	292.5	394	435	552.5	607.5	720	820	915	
K	85	89	89	108	110	140	140	179	188	203	230	240	
K1	43	51	52	63	61	85	87	90	100	100	120	125	
K2	42	47	58	62	60	100	102	112	140	155	176	200	
L	70	83	92	113	125	155	197	230	264	300	368	395	
L1	135	148	157	178	193	223	265	298	332	368	495	545	
蜗轮箱与电装组合参数 COMBINATION OF WORM GEAR BOX AND ELECTRICAL EQUIPMENT PARAMETERS													
电装参数 Electrical Parameters	力矩 Torque Nm	108	108	108	203	244	540	845	1020	2030	2030	3000	5000
	转速 Speed r/min	24	24	24	24	48	36	36	24	36	24	24	24
	接盘 JB2920-81	Z10	Z10	Z10	Z20	Z30	Z60	Z90	Z120	Z250	Z250	Z350	Z500
蜗轮参数 Gearbox Parameters	接盘 Connection flange	F10	F10	F10	F14	F14	F16	F16	F25	F25	F30	F30	F35
	输出力矩 Output Nm	750	1200	1490	3000	4400	9700	15700	20500	40000	45000	76500	116000
	开阀时间 Open-time S	21	24	29	31	19	25	26	42	27	49	44	50