

该系列是一款90°部分回转手动驱动装置。适用于球阀、蝶阀、旋塞阀、旋球阀等阀门。箱体采用精密铸造，样式新颖，外形美观。采用蜗轮蜗杆传动，蜗轮副自锁，使用圆锥滚子轴承，传动更加灵活，效率高。蜗轮与阀门阀杆连接部分有实体和内置螺母两款供客户选择，法兰全部采用 ISO5211 国际标准，与阀门配套更加方便。防护等级为IP65。

This series of products is quarter turn manual gear actuator. Suit to be used in ball valves, butterfly valves, plug valves, rotary ball valves etc. The housing made by precise casting, new design, nice appearance. It transmitted by worm gear and worm. The worm gear with self-locking. With tapered roller bearing, so the gearboxes can be operated more flexibly and have higher efficiency. Two connection types for choose: stem and key connection and removable nut type. The mounting flange adapts to ISO 5211. So the gearboxes installed on the valve are very convenient. General products protection grade is IP65.

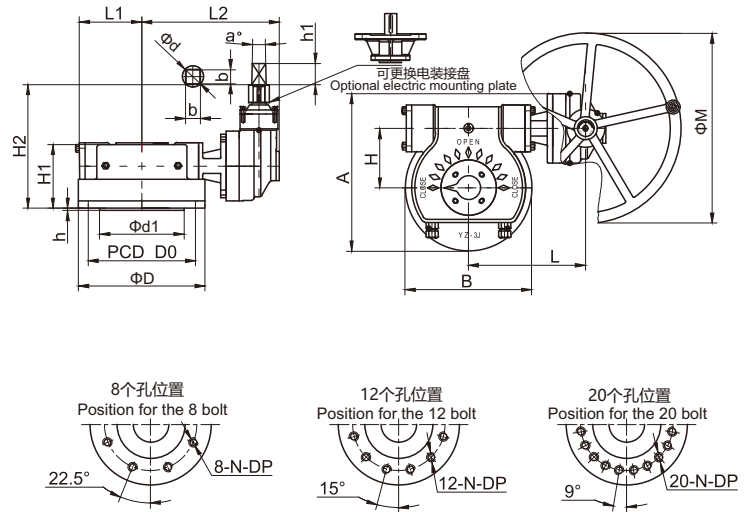

型号 Model	YZ-1-G	YZ-2-G	YZ-2J-G	YZ-3-G	YZ-3J-G	YZ-4-G	YZ-4J-G	YZ-5-G	YZ-5J-G	YZ-6-G	YZ-6J-G	YZ-7-G	YZ-7X-G	YZ-7J-G	YZ-8-G	YZ-8J-G	YZ-9-G	YZ-9J-G	YZ-10-G	
技术参数 TECHNICAL-PARAMETERS																				
速比 Ratio	102:1	102:1	112:1	118:1	345:1	380:1	740:1	855:1	870:1	1170:1	1350:1	2952:1	2946:1	3240:1	4725:1	5940:1	8300:1	7308:1	13150:1	
最大转矩 Max-torque N-m	1200	2000	3000	4500	7500	12000	16500	23000	28000	32000	48000	63000	80000	100000	140000	190000	250000	350000	400000	
输入扭矩 input torque N-m	60	90	130	190	125	175	120	155	160	150	175	150	150	195	190	160	190	240	190	
最大阀杆mm (Φd) Max-Stem-Diameter	42 12×8	50 14×9	60 18×11	60 18×11	75 22×14	90 25×14	110 28×16	110 28×16	120 32×18	120 32×18	145 40×22	160 40×22	170 45×25	180 45×25	200 45×25	210 50×28	200 50×28	270 63×32	300 70×36	
连接尺寸 CONNECTION-SIZE																				
法兰号 Flange	F12	F14	F16	F16	F20	F25	F30	F30	F35	F35	F40	F40	F48	F48	F48	F60	F60	F60	F80	
法兰外圆(D)	150	175	210	210	250	300	350	350	415	415	475	475	560	560	560	686	686	686	900	
连接孔中心 PCD	D0	125	140	165	165	205	254	298	298	356	356	406	406	483	483	483	603	603	603	813
	N-H-DP	4-M12 -18	4-M16 -20	4-M20 -30	4-M20 -30	8-M16 -24	8-M16 -24	8-M20 -30	8-M20 -30	8-M30 -45	8-M30 -40	8-M36 -54	8-M36 -54	12-M36 -54	12-M36 -54	12-M36 -54	20-M36 -54	20-M36 -54	20-M36 -54	20-M42 -65
凸面Convex (D1×h)	85×3	100×4	130×5	130×5	140×5	200×5	230×5	230×5	260×5	260×5	300×8	300×8	370×8	370×8	370×8	470×8	470×8	470×8	670×10	
外形尺寸 APPEARANCE-SIZE																				
A	217.5	240	269.5	296.5	373	423	450	460	555	595	682	715	740	770	894.5	965	1056	1290	1405	
B	150	175	210	225	300	340	350	390	430	470	555	590	620	660	730	770	800	1030	1150	
L	212	222	242	253	277	289.5	333.5	336	558.5	571	627	637	657	682	704.5	809	807	854.5	924.5	
L1	85	95	115	122	147.5	167.5	185	187.5	225	232.5	280	295	315	340	360	395	417.5	530	475	
L2	257	267	287	301	325	334.5	382	384.5	602	614.5	689.5	690	719.5	735	778	831	880.5	928	998	
H	70	80	92	104	140	160	170	160	200	220	262	280	290	300	342	360	535	495	550	
H1	100.5	110	128.5	150	150	177.5	184.5	182.5	190	195	235	235	262	274	295	368	392	428	405	
H2	246.5	256.5	270	291.5	286.5	327.5	340.5	338.5	351	346	403	404	426	444	482	497	524	543	537	
h1	50	50	50	50	50	50	50	50	50	50	50	50	50	50	50	50	50	50	50	
b	35	35	35	35	35	35	35	35	35	35	35	35	35	35	35	35	35	35	35	
Φd	50	50	50	50	50	50	50	50	50	50	50	50	50	50	50	50	50	50	50	
a	4	4	4	4	4	4	4	4	4	4	4	4	4	4	4	4	4	4	4	
ΦM	350	350	400	400	400	500	500	500	500	500	600	600	600	600	650	700	700	800	800	