

RK-DZ

多回转型阀门手动装置

RK-DZ Series Multi-turn manual gear actuator



该装置是直接安装在闸阀、蝶阀、旋塞阀和截止阀等阀门上的手动装置，该装置采用弧齿锥齿轮和平面推力轴承，有运转平稳、扭矩大、噪音小、效率高的优点。在所有的结合部，采用了密封垫全密封处理，达到了防水、防油漏的效果，防护等级为IP65。手轮和阀杆罩可根据用户需求定制。结合各类阀门使用要求及环境，还有单级带电装连接、双级带电装连接、双级手轮驱动等产品。

This bevel gearbox can be installed directly on the gate valves, butterfly valves, plug valves, globe valves and other valves. By using spiral bevel gears and thrust ball bearing, this series actuator can run smoothly, and has high output torque, low noise and high efficiency. It can avoid from water in and grease out. Protection grade is IP65. For special environment can be done IP68 and immersion. Handwheel and stem cover can be customized. For different valves and requirement, there are single stage gearboxes with input flange, two stage gearboxes with input flange, two stage manual gearboxes and so on.

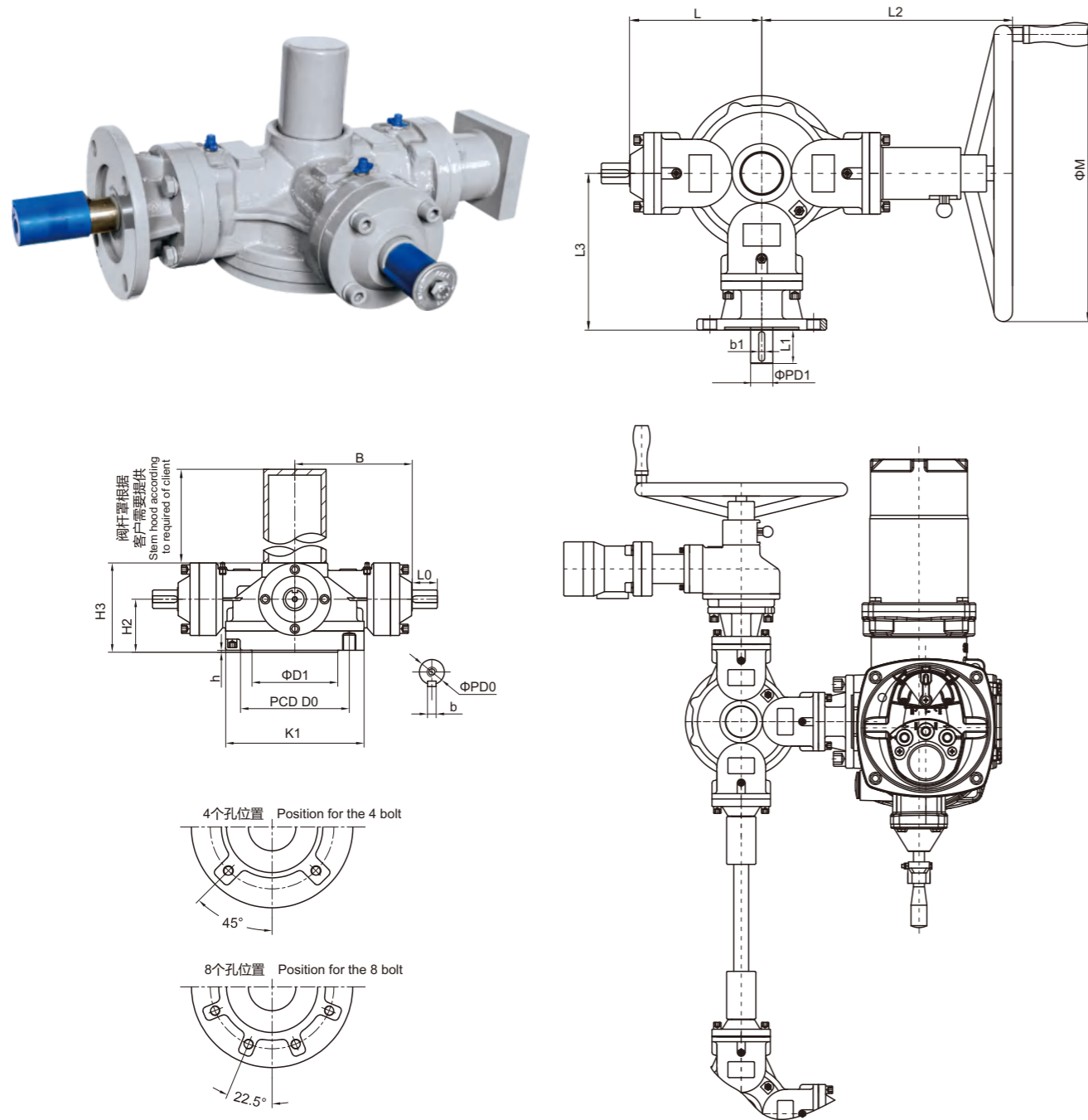

RK-DZ

多回转型阀门手动装置

RK-DZ Series Multi-turn manual gear actuator



型号 Model	RK03-DZ	RK05-DZ	RK1-DZ	2CK2-DZ	2CK3-DZ	2CK5-DZ	2CK8-DZ	2CK10-DZ	
技术参数 TECHNICAL-PARAMETERS									
速比 Ratio	2.6:1	3:1	3.6:1	4.2:1	4.2:1	5:1	6.3:1	7.1:1	
最大推力 Max-thrust	N·m	90000	135000	180000	250000	280000	370000	650000	880000
	Kgf·m	9184	13776	18367	25510	28571	37755	66327	89796
最大转矩 Max-torque	N·m	350	550	900	1500	2000	2800	4500	6800
	Kgf·m	36	56	92	153	204	286	459	694
最大阀杆直径 Max-stem dia. Mm	42	52	60	70	80	95	110	130	
参考重量 Weight Kg	18	25	28	33	48	92.5	190	280	
连接尺寸 CONNECTION-SIZE									
法兰号 Flange	F12	F14	F16	(F20)	F25	F30	F35	F40	
法兰外圆(D)	150	175	210	250	300	350	415	475	
连接孔中心PCD	D0	125	140	165	205	254	298	356	406
	N-H-DP	4-M12-18	4-M16-24	4-M20-30	8-M16-24	8-M16-24	8-M20-30	8-M30-45	8-M36-54
凸面 Convex (D1×h)	85×3	100×4	130×4	140×5	200×5	230×5	260×5	300×8	
外形尺寸 APPEARANCE-SIZE									
H1	45	69	76	89	97	120	150	176	
H2	84	96	113	113	127	163	225	290	
H3	110	123	138	140	152	188	250	320	
L	152	170	180	202	226	280	355	365	
L2	275	350	370	342	366	440	515	675	
手轮handwheel	PD0	20	28	28	32	32	38	50	
	(b)key	6×6	8×7	8×7	10×8	10×8	10×8	10×8	2-16×10
	L0	26	40	50	38	38	44	44	50
	M	300	400	500	550	600	700	800	800
与电装连接 Input Shaft	PD1X(b1)key	20×6	30×8	30×8	30×8	40×12	45×14	50×14	50×14
	L1	45	50	50	50	60	65	65	70
与电装连接法兰号JB2920-81 Input flange size	1号法兰 Flange No.1	2号法兰 Flange No.2	3号法兰 Flange No.3	4号法兰 Flange No.4	4号法兰 Flange No.4	5号法兰 Flange No.5	7号法兰 Flange No.7	8号法兰 Flange No.8	
外形尺寸 APPEARANCE-SIZE									
H1	46	55	62	75	85	105	145	165	
H2	70	70	75	90	100	140	155	210	
H3	125	128	145	160	170	225	280	335	
L3	175	200	220	248	265	320	395	405	
伞齿轮与电装组合参数 BEVEL GEAR COMBINATION OF PARAMETERS AND ELECTRICAL EQUIPMEN									
电装参数 Electrical Parameters	输入力矩input Torque Nm	200	250	300	450	600	900	1800	2000
	转速Speed r/min	36	36	36	24/48	24/36/48	24/36/48	24/36	24/36
	接盘Connection flange F	F10	F14	F14	F14	F16	F16	F25	F30
伞齿轮参数 Parameters of bevel gear	输出力矩Output Torque Nm	375	600	864	1440	2040	3700	9000	11200