

该装置是直接安装在气缸上的手动装置，该装置采用弧齿锥齿轮和平面推力轴承，有运转平稳、扭矩大、噪音小、效率高的优点。在所有的结合部，采用了密封垫全密封处理，达到了防水、防油漏的效果，防护等级为IP65。该装置在没有气源的情况下可手动切换手柄，转换成手动直接操作，产品还可根据推力大小安装二级减速器。

The manual gear actuator can be installed directly on the pneumatic. By using Spiral bevel gears and thrust ball bearing, the gear actuator can run smoothly, and have high output torque, low noise and high efficiency. It can avoid from waterproof & oil leakage as sealing glands are used at all the through part. Protection grade can be IP65. When have no air source, can manual switch to handle direct operation. Also can install second stage gearbox according to the thrust.

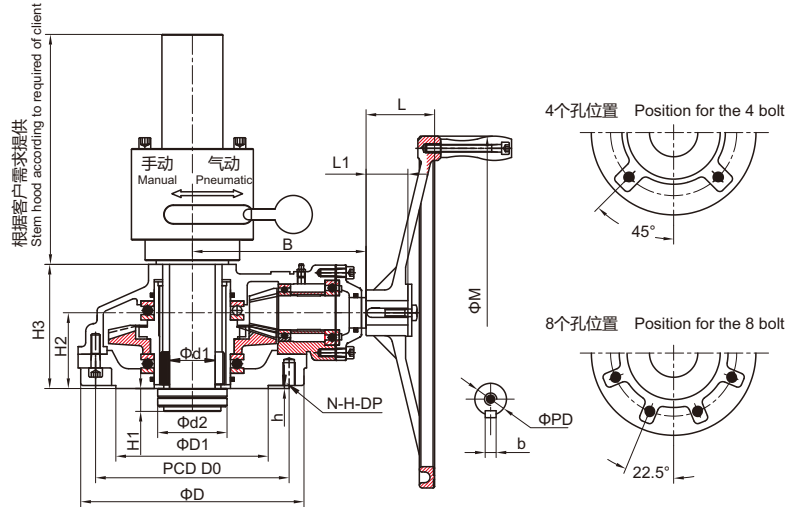

型号Model	BA-000-Q	BA-00-Q	BA-0-Q	BA-1-Q	BA-2-Q	BA-3-Q	BAA-3-Q	
技术参数 TECHNICAL-PARAMETERS								
速比 Ratio	2.35:1	3:01	3.6:1	4.5:1	5.2:1	6.3:1	23:01	
最大扭矩 Max-torque Nm	360	480	735	1470	2940	4000	6000	
最大推力 Max-thrust N	43000	64000	98000	196000	340000	490000	630000	
最大阀杆直径d1 Max-stem dia. Mm	25	30	40	52	70	90	110	
闸阀 Gate-valve DN	50	80-100	150-200	250-400	450-700	800-1000	1200	
截止阀 Globe-valve DN	50	80	100-150	200-250	300-350	400-500	550-650	
法兰外圆(D)	15	22	28	54	110	198	320	
连接尺寸 CONNECTION-SIZE								
连接孔中心 PCD	D0	125	140	165	254	298	356	356
	N-H-DP	4-M12-18	4-M16-24	4-M20-30	8-M16-24	8-M20-30	8-M30-45	8-M30-45
凸面 Convex (D1×h)		85×3	100×4	130×5	200×5	230×5	260×5	260×5
外形尺寸 APPEARANCE-SIZE								
B		150	150	170	233	306	370	395
H1		25	25	25	35	35	45	45
H2		80	80	85	97	142	160	178
H3		125	125	155	175	210	280	290
L		40	75	92	107	107	118	118
手轮handwheel	PD	28	28	28	32	32	38	38
	(b)key	8×7	8×7	8×7	10×8	10×8	10×8	10×8
	L1	40	40	40	50	55	55	55
	M	300	300	400	460	520	600	600